

# **Chapter 11**

## **Refrigeration Cycles**

### **Study Guide in PowerPoint**

**to accompany**

**Thermodynamics: An Engineering Approach, 7th edition  
by Yunus A. Çengel and Michael A. Boles**

The vapor compression refrigeration cycle is a common method for transferring heat from a low temperature to a high temperature.

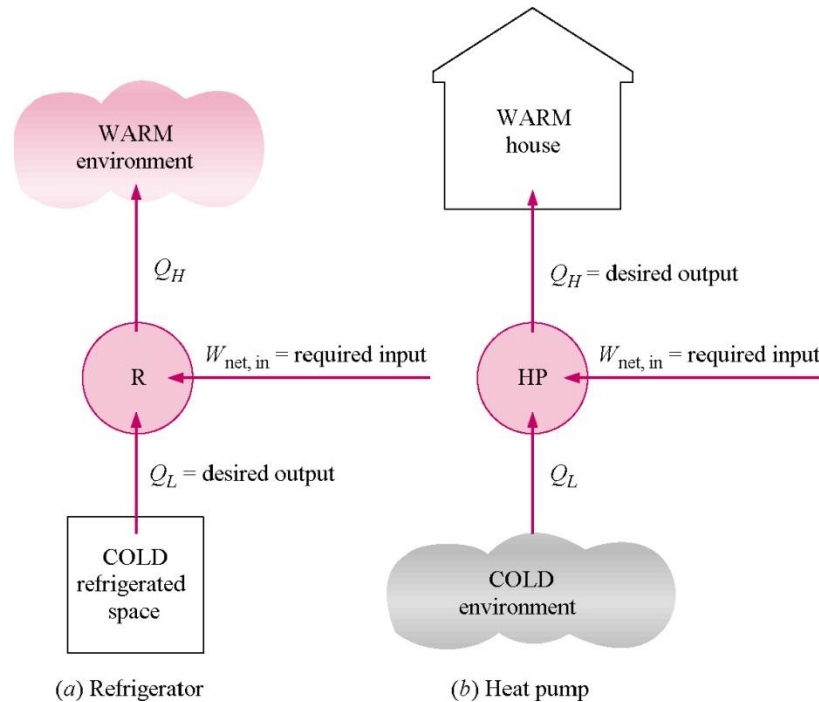

The above figure shows the objectives of refrigerators and heat pumps. The purpose of a refrigerator is the removal of heat, called the cooling load, from a low-temperature medium. The purpose of a heat pump is the transfer of heat to a high-temperature medium, called the heating load. When we are interested in the heat energy removed from a low-temperature space, the device is called a refrigerator. When we are interested in the heat energy supplied to the high-temperature space, the device is called a heat pump. In general, the term heat pump is used to describe the cycle as heat energy is removed from the low-temperature space and rejected<sub>2</sub> to the high-temperature space.

The performance of refrigerators and heat pumps is expressed in terms of *coefficient of performance* (COP), defined as

$$COP_R = \frac{\text{Desired output}}{\text{Required input}} = \frac{\text{Cooling effect}}{\text{Work input}} = \frac{Q_L}{W_{net,in}}$$
$$COP_{HP} = \frac{\text{Desired output}}{\text{Required input}} = \frac{\text{Heating effect}}{\text{Work input}} = \frac{Q_H}{W_{net,in}}$$

Both  $COP_R$  and  $COP_{HP}$  can be larger than 1. Under the same operating conditions, the COPs are related by

$$COP_{HP} = COP_R + 1$$

Can you show this to be true?

Refrigerators, air conditioners, and heat pumps are rated with a SEER number or seasonal adjusted energy efficiency ratio. The SEER is defined as the Btu/hr of heat transferred per watt of work energy input. The Btu is the British thermal unit and is equivalent to 778 ft-lbf of work ( $1 \text{ W} = 3.4122 \text{ Btu/hr}$ ). An EER of 10 yields a COP of 2.9.

Refrigeration systems are also rated in terms of tons of refrigeration. One ton of refrigeration is equivalent to 12,000 Btu/hr or 211 kJ/min. How did the term “ton of cooling” originate?

For more information and animations illustrating this topic visit the Animation Library developed by Professor S. Bhattacharjee, San Diego State University, at this link.

[test.sdsu.edu/testhome/vtAnimations/index.html](http://test.sdsu.edu/testhome/vtAnimations/index.html)

### Reversed Carnot Refrigerator and Heat Pump

Shown below are the cyclic refrigeration device operating between two constant temperature reservoirs and the  $T$ - $s$  diagram for the working fluid when the reversed Carnot cycle is used. Recall that in the Carnot cycle heat transfers take place at constant temperature. If our interest is the cooling load, the cycle is called the Carnot refrigerator. If our interest is the heat load, the cycle is called the Carnot heat pump.

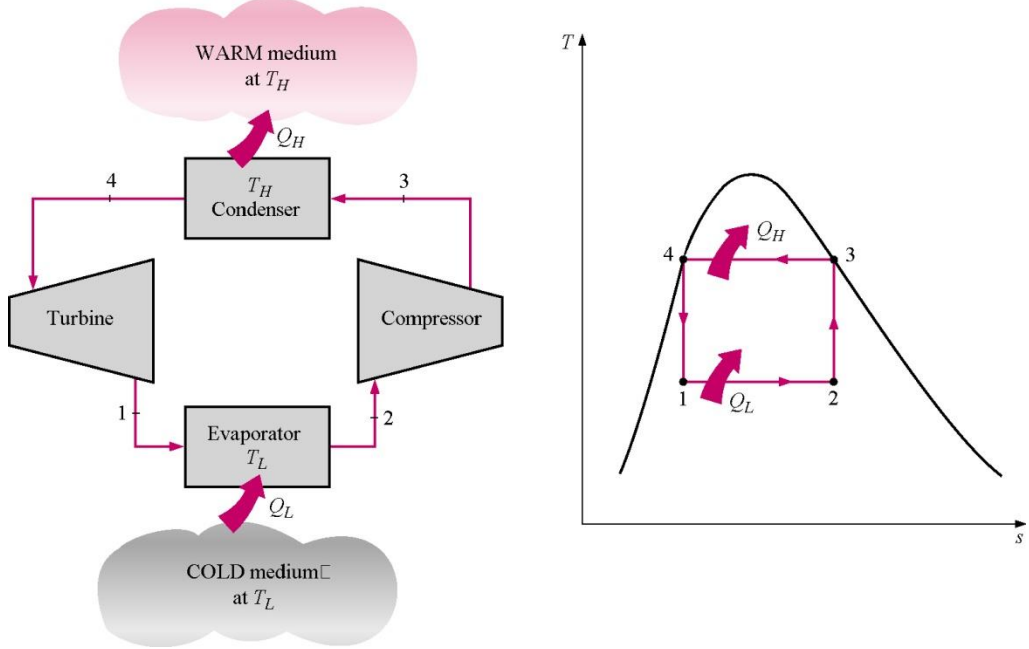

The standard of comparison for refrigeration cycles is the *reversed Carnot cycle*. A refrigerator or heat pump that operates on the reversed Carnot cycle is called a *Carnot refrigerator* or a *Carnot heat pump*, and their COPs are

$$COP_{R,Carnot} = \frac{1}{T_H / T_L - 1} = \frac{T_L}{T_H - T_L}$$
$$COP_{HP,Carnot} = \frac{1}{1 - T_L / T_H} = \frac{T_H}{T_H - T_L}$$

Notice that a turbine is used for the expansion process between the high and low-temperatures. While the work interactions for the cycle are not indicated on the figure, the work produced by the turbine helps supply some of the work required by the compressor from external sources.

Why not use the reversed Carnot refrigeration cycle?

- Easier to compress vapor only and not liquid-vapor mixture.
- Cheaper to have irreversible expansion through an expansion valve.

What problems result from using the turbine instead of the expansion valve?

# The Vapor-Compression Refrigeration Cycle

The vapor-compression refrigeration cycle has four components: evaporator, compressor, condenser, and expansion (or throttle) valve. The most widely used refrigeration cycle is the *vapor-compression refrigeration cycle*. In an ideal vapor-compression refrigeration cycle, the refrigerant enters the compressor as a saturated vapor and is cooled to the saturated liquid state in the condenser. It is then throttled to the evaporator pressure and vaporizes as it absorbs heat from the refrigerated space.

The ideal vapor-compression cycle consists of four processes.

## Ideal Vapor-Compression Refrigeration Cycle

Process	Description
1-2	Isentropic compression
2-3	Constant pressure heat rejection in the condenser
3-4	Throttling in an expansion valve
4-1	Constant pressure heat addition in the evaporator

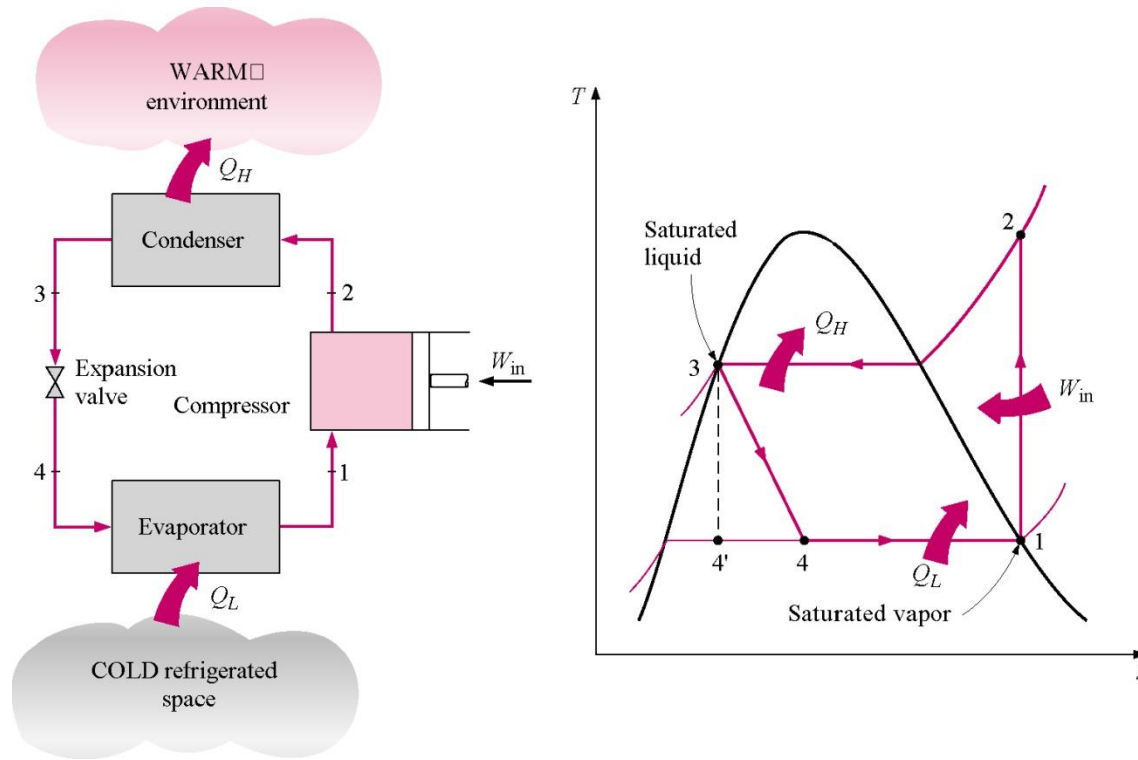

The  $P-h$  diagram is another convenient diagram often used to illustrate the refrigeration cycle.

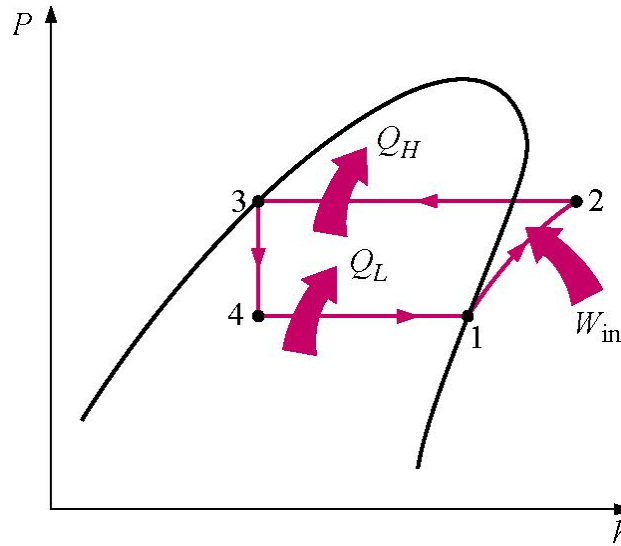

The ordinary household refrigerator is a good example of the application of this cycle.

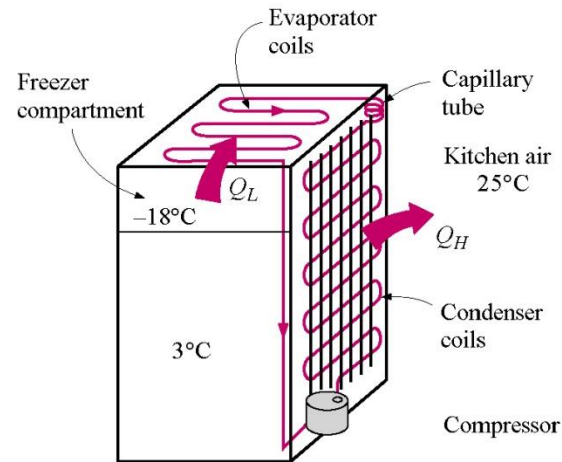

### Results of First and Second Law Analysis for Steady-Flow

Component	Process	First Law Result
Compressor	$s = \text{const.}$	$\dot{W}_{in} = \dot{m}(h_2 - h_1)$
Condenser	$P = \text{const.}$	$\dot{Q}_H = \dot{m}(h_2 - h_3)$
Throttle Valve	$\Delta s > 0$	$h_4 = h_3$
	$\dot{W}_{net} = 0$	
	$\dot{Q}_{net} = 0$	
Evaporator	$P = \text{const.}$	$\dot{Q}_L = \dot{m}(h_1 - h_4)$

$$COP_R = \frac{\dot{Q}_L}{\dot{W}_{net,in}} = \frac{h_1 - h_4}{h_2 - h_1}$$

$$COP_{HP} = \frac{\dot{Q}_H}{\dot{W}_{net,in}} = \frac{h_2 - h_3}{h_2 - h_1}$$



## Example 11-1

Refrigerant-134a is the working fluid in an ideal compression refrigeration cycle. The refrigerant leaves the evaporator at  $-20^{\circ}\text{C}$  and has a condenser pressure of  $0.9\text{ MPa}$ . The mass flow rate is  $3\text{ kg/min}$ . Find  $\text{COP}_R$  and  $\text{COP}_{R, \text{Carnot}}$  for the same  $T_{\text{max}}$  and  $T_{\text{min}}$ , and the tons of refrigeration.

Using the Refrigerant-134a Tables, we have

$$\left. \begin{array}{l} \text{State 1} \\ \text{Compressor inlet} \\ T_1 = -20^{\circ}\text{C} \\ x_1 = 1.0 \end{array} \right\} \left\{ \begin{array}{l} h_1 = 238.41 \frac{\text{kJ}}{\text{kg}} \\ s_1 = 0.9456 \frac{\text{kJ}}{\text{kg} \cdot \text{K}} \end{array} \right.$$

$$\left. \begin{array}{l} \text{State 2} \\ \text{Compressor exit} \\ P_{2s} = P_2 = 900\text{ kPa} \\ s_{2s} = s_1 = 0.9456 \frac{\text{kJ}}{\text{kg} \cdot \text{K}} \end{array} \right\} \left\{ \begin{array}{l} h_{2s} = 278.23 \frac{\text{kJ}}{\text{kg}} \\ T_{2s} = 43.79^{\circ}\text{C} \end{array} \right.$$

$$\left. \begin{array}{l} \text{State 3} \\ \text{Condenser exit} \\ P_3 = 900\text{ kPa} \\ x_3 = 0.0 \end{array} \right\} \left\{ \begin{array}{l} h_3 = 101.61 \frac{\text{kJ}}{\text{kg}} \\ s_3 = 0.3738 \frac{\text{kJ}}{\text{kg} \cdot \text{K}} \end{array} \right.$$

$$\left. \begin{array}{l} \text{State 4} \\ \text{Throttle exit} \\ T_4 = T_1 = -20^{\circ}\text{C} \\ h_4 = h_3 \end{array} \right\} \left\{ \begin{array}{l} x_4 = 0.358 \\ s_4 = 0.4053 \frac{\text{kJ}}{\text{kg} \cdot \text{K}} \end{array} \right.$$

$$\begin{aligned}
COP_R &= \frac{\dot{Q}_L}{\dot{W}_{net,in}} = \frac{\dot{m}(h_1 - h_4)}{\dot{m}(h_2 - h_1)} = \frac{h_1 - h_4}{h_2 - h_1} \\
&= \frac{(238.41 - 101.61) \frac{kJ}{kg}}{(278.23 - 238.41) \frac{kJ}{kg}} \\
&= 3.44
\end{aligned}$$

The tons of refrigeration, often called the cooling load or refrigeration effect, are

$$\begin{aligned}
\dot{Q}_L &= \dot{m}(h_1 - h_4) \\
&= 3 \frac{kg}{min} (238.41 - 101.61) \frac{kJ}{kg} \frac{1Ton}{211 \frac{kJ}{min}} \\
&= 1.94Ton
\end{aligned}$$

$$\begin{aligned}
COP_{R, Carnot} &= \frac{T_L}{T_H - T_L} \\
&= \frac{(-20 + 273) K}{(43.79 - (-20)) K} \\
&= 3.97
\end{aligned}$$

Another measure of the effectiveness of the refrigeration cycle is how much input power to the compressor, in horsepower, is required for each ton of cooling.

The unit conversion is 4.715 hp per ton of cooling.

$$\begin{aligned}\frac{\dot{W}_{net, in}}{\dot{Q}_L} &= \frac{4.715}{COP_R} \\ &= \frac{4.715 \text{ hp}}{3.44 \text{ Ton}} \\ &= 1.37 \frac{\text{hp}}{\text{Ton}}\end{aligned}$$

# Actual Vapor-Compression Refrigeration Cycle

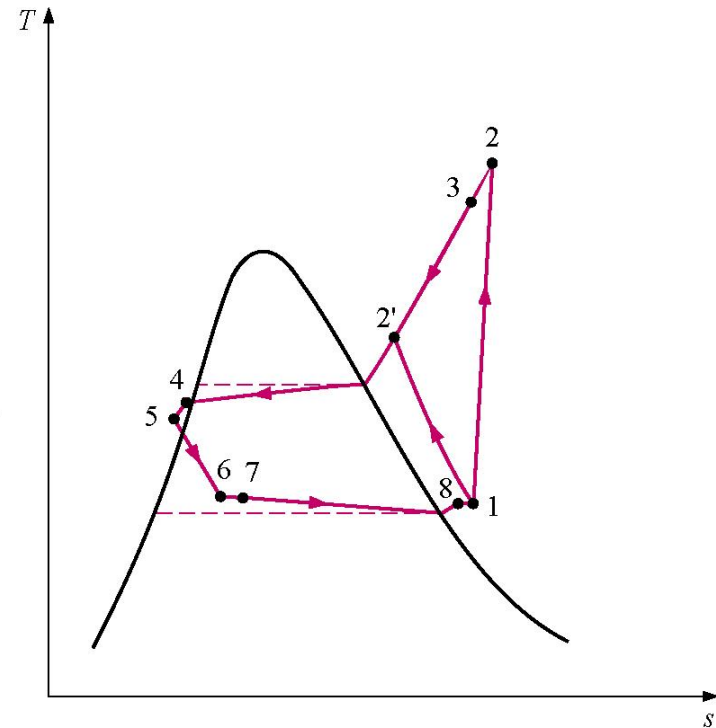
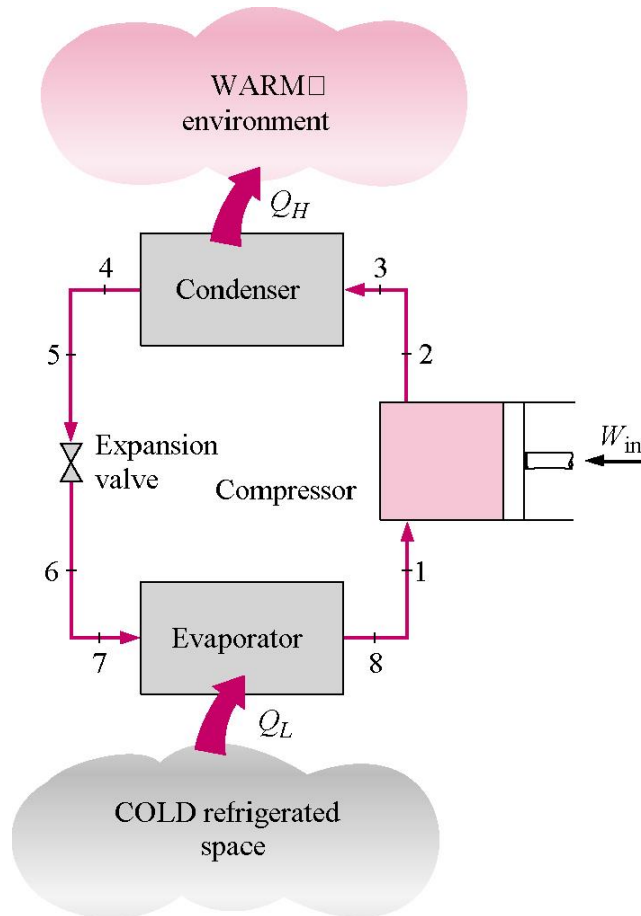

# Heat Pump Systems

## HEAT PUMP OPERATION – HEATING MODE

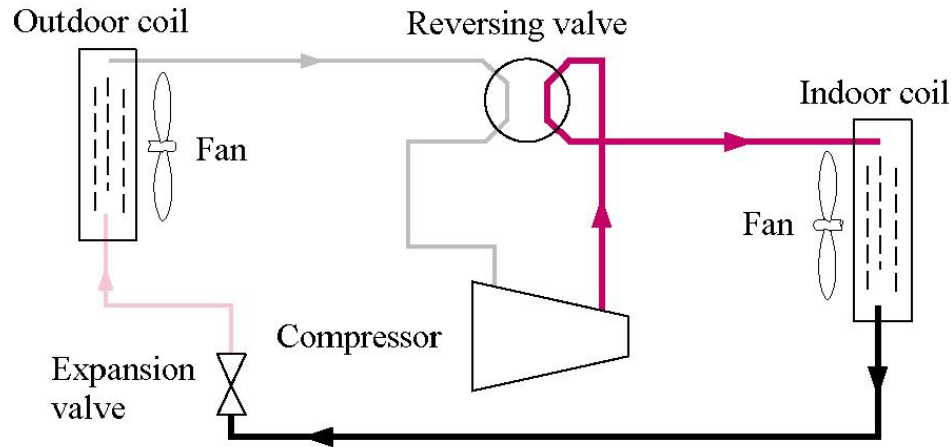

- High-pressure liquid
- Low-pressure liquid-vapor
- Low-pressure vapor
- High-pressure vapor

## HEAT PUMP OPERATION – COOLING MODE

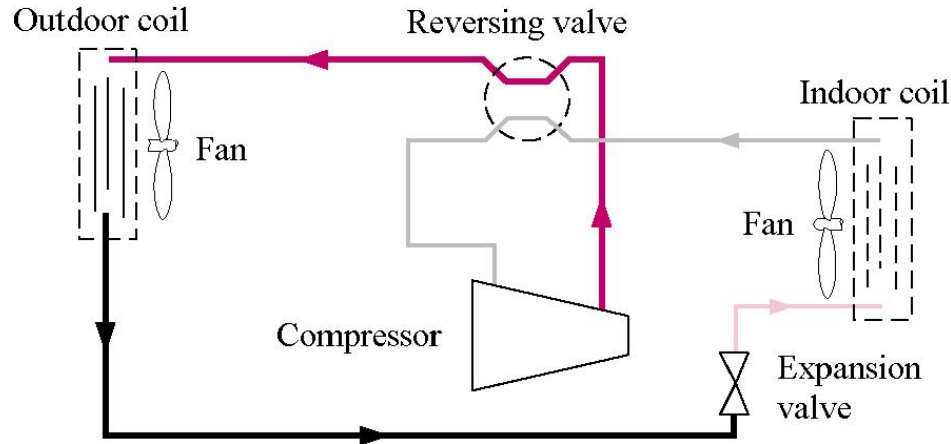

# Other Refrigeration Cycles

## Cascade refrigeration systems

Very low temperatures can be achieved by operating two or more vapor-compression systems in series, called *cascading*. The COP of a refrigeration system also increases as a result of cascading.

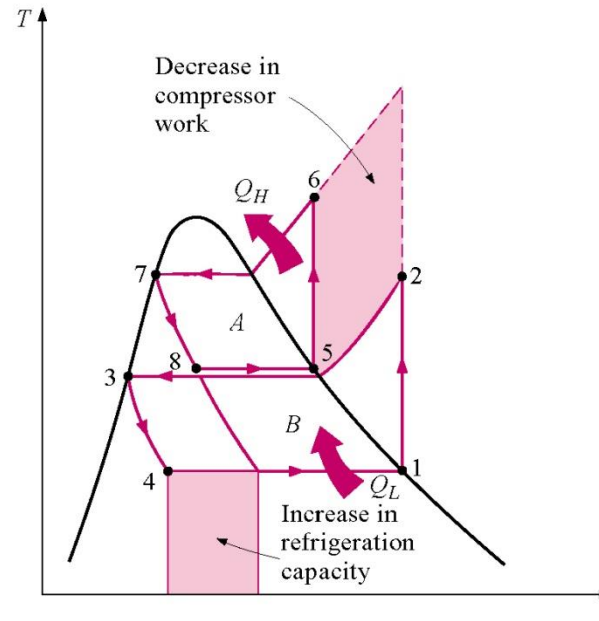
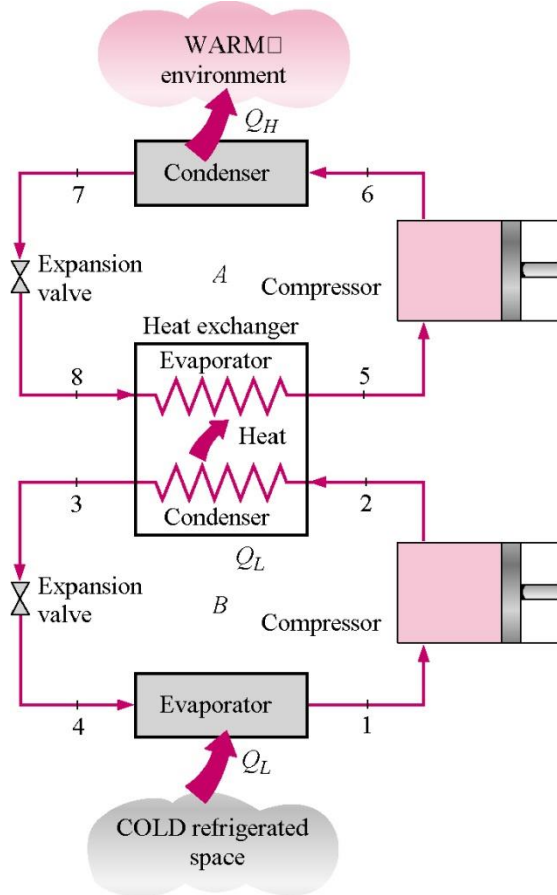

# Multistage compression refrigeration systems

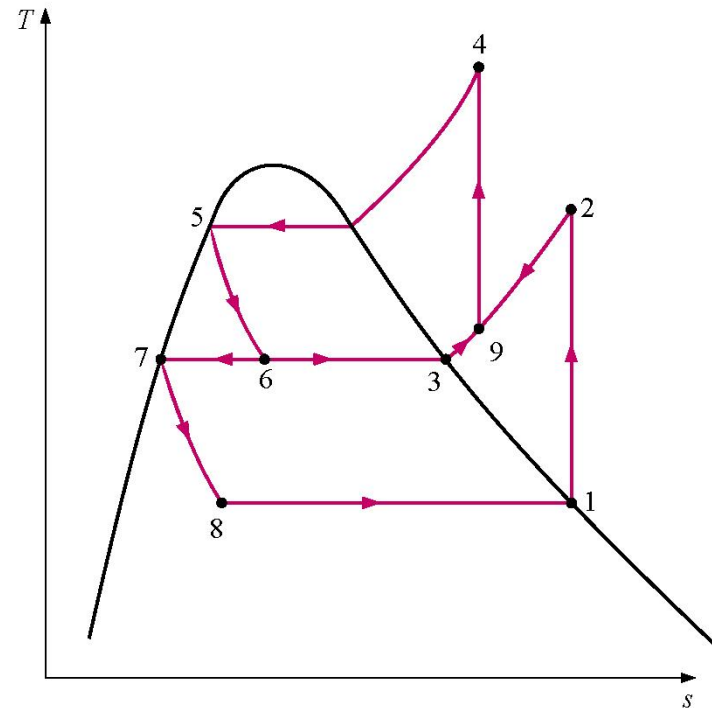
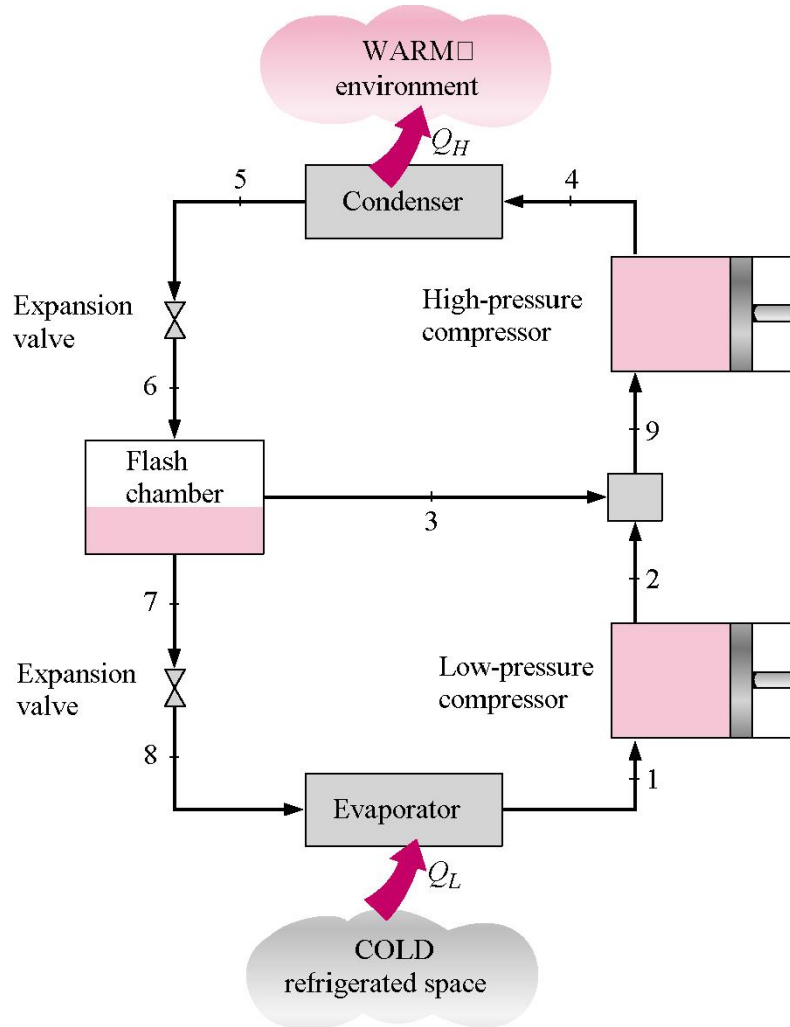

# Multipurpose refrigeration systems

A refrigerator with a single compressor can provide refrigeration at several temperatures by throttling the refrigerant in stages.

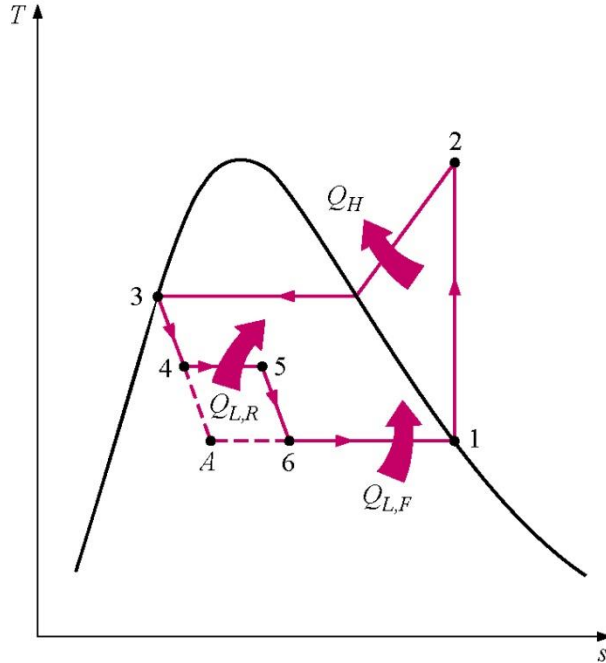
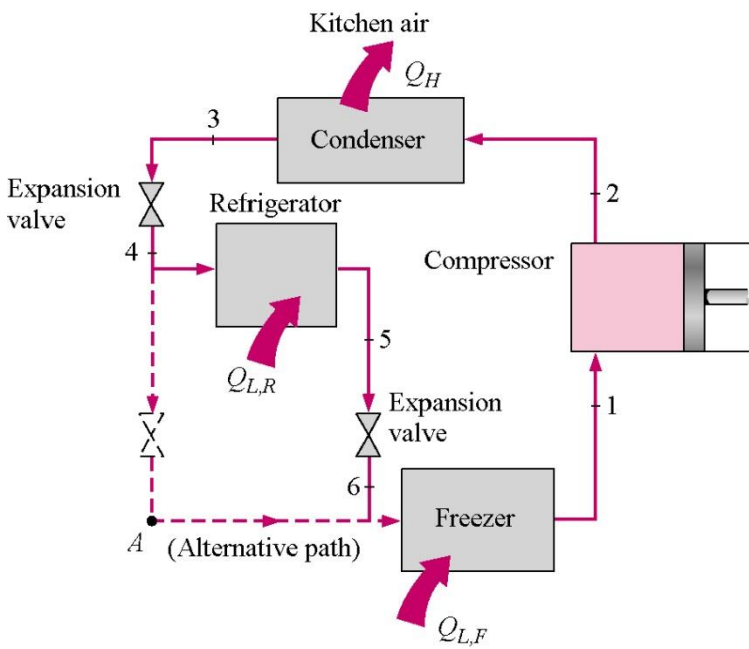



# Liquefaction of gases

Another way of improving the performance of a vapor-compression refrigeration system is by using *multistage compression with regenerative cooling*. The vapor-compression refrigeration cycle can also be used to liquefy gases after some modifications.

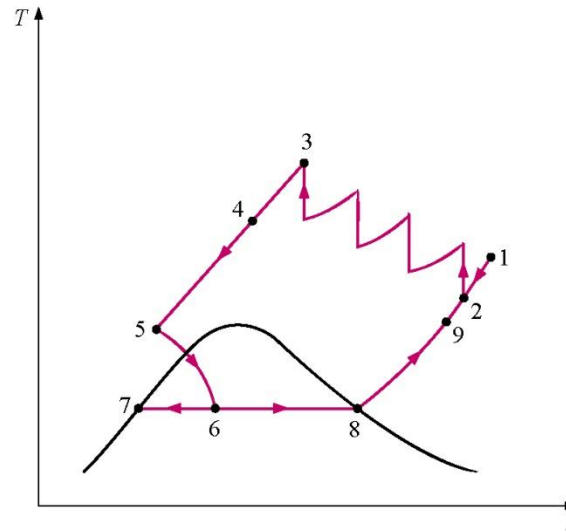
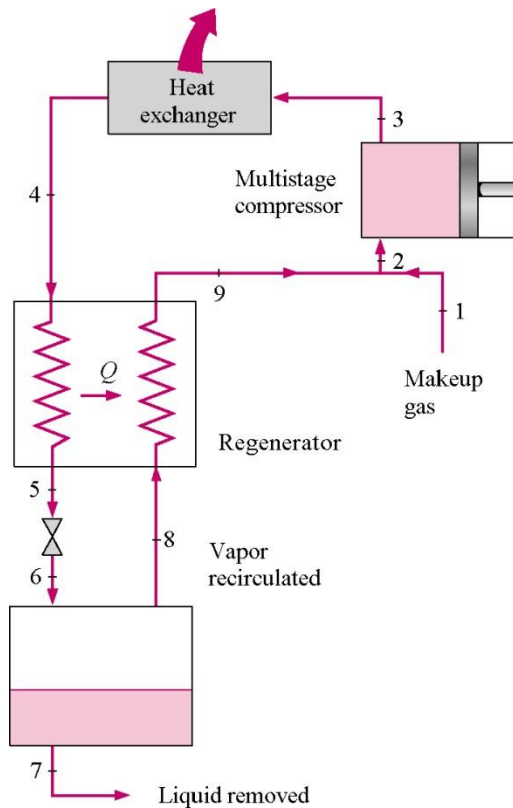

# Gas Refrigeration Systems

The power cycles can be used as refrigeration cycles by simply reversing them. Of these, the *reversed Brayton cycle*, which is also known as the *gas refrigeration cycle*, is used to cool aircraft and to obtain very low (cryogenic) temperatures after it is modified with regeneration. The work output of the turbine can be used to reduce the work input requirements to the compressor. Thus, the COP of a gas refrigeration cycle is

$$COP_R = \frac{q_L}{W_{net,in}} = \frac{q_L}{W_{comp,in} - W_{turb,out}}$$

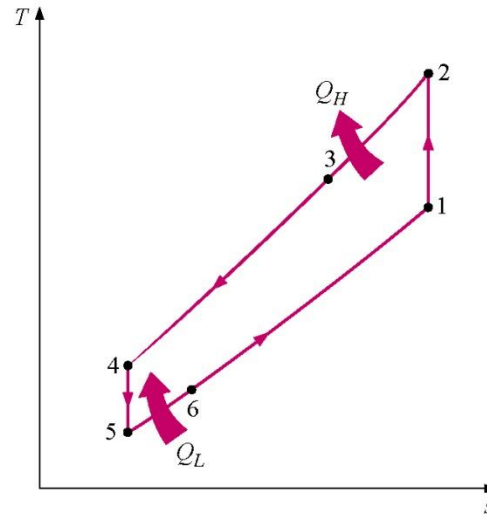
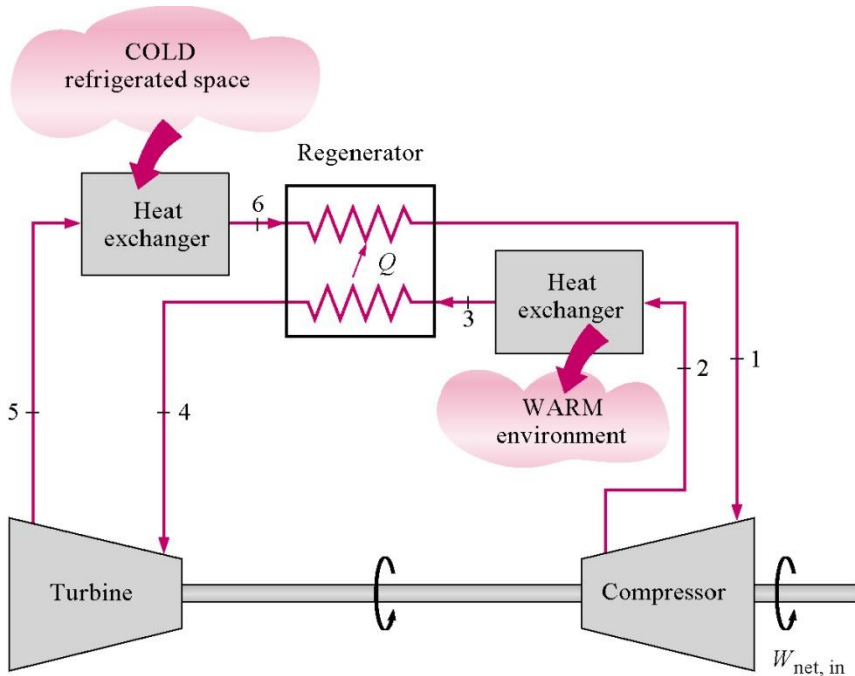

# Absorption Refrigeration Systems

Another form of refrigeration that becomes economically attractive when there is a source of inexpensive heat energy at a temperature of 100 to 200°C is *absorption refrigeration*, where the refrigerant is absorbed by a transport medium and compressed in liquid form. The most widely used absorption refrigeration system is the ammonia-water system, where ammonia serves as the refrigerant and water as the transport medium. The work input to the pump is usually very small, and the COP of absorption refrigeration systems is defined as

$$COP_R = \frac{\text{Desired output}}{\text{Required input}} = \frac{\text{Cooling effect}}{\text{Work input}} = \frac{Q_L}{Q_{gen} + W_{pump,in}} \cong \frac{Q_L}{Q_{gen}}$$

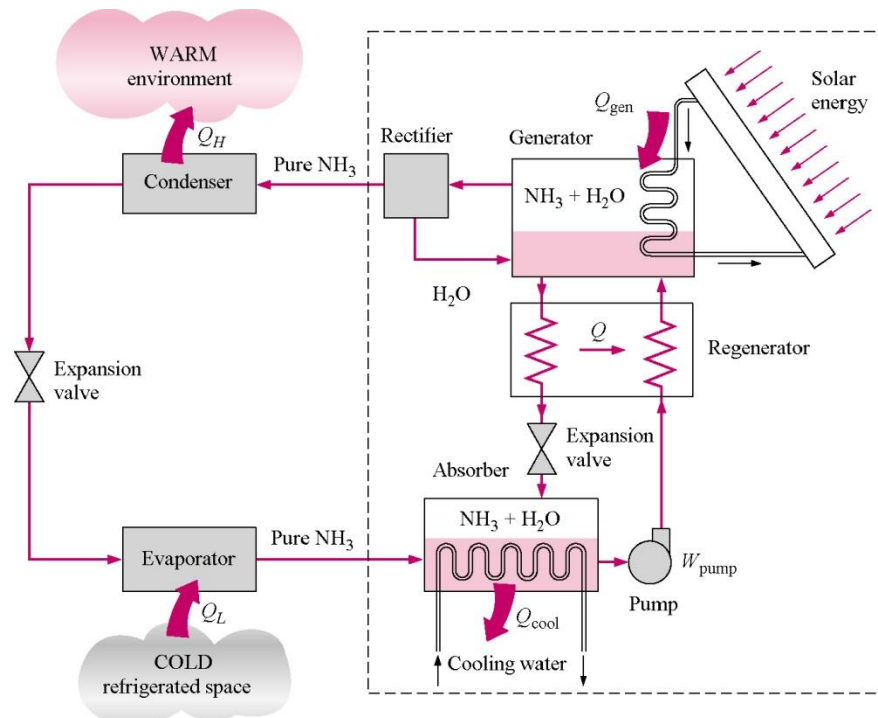

# Thermoelectric Refrigeration Systems

A refrigeration effect can also be achieved without using any moving parts by simply passing a small current through a closed circuit made up of two dissimilar materials. This effect is called the *Peltier effect*, and a refrigerator that works on this principle is called a *thermoelectric refrigerator*.

